

Midea Breezeless

FICHA PRODUCTO

 RG58N2(B2H)/BGEF
 Control incluido de serie



Producto certificado por:



CARACTERÍSTICAS

| Modelo | BREEZELESS 26(09)N8H | BREEZELESS 35(12)N8H |
|---------------------------------|-------------------------------|-------------------------------|
| Capacidad frigorífica | 2,63 kW | 3,52 kW |
| Consumo frío | 640 W | 850 W |
| Capacidad calorífica | 2,93 kW | 3,81 kW |
| Consumo calor | 630 W | 950 W |
| Clasificación ErP frío/calor | A+++ / A++ | A+++ / A++ |
| Caudal de aire (int.) | 380/500/610 m ³ /h | 400/520/640 m ³ /h |
| Presión sonora (int.) | 19/20,50/35/38 dB(A) | 20,50/21/35,50/38,80 dB(A) |
| Caudal de aire (ext.) | 2.000 m ³ /h | 2.000 m ³ /h |
| Presión sonora (ext.) | 55 dB(A) | 55,50 dB(A) |
| Alimentación | 220-240 V / 1 / 50 Hz | |
| Cableado alimentación (ext.) | (2+T)x1,50 mm ² | (2+T)x1,50 mm ² |
| Cableado comunicación | (4+T)x1,50 mm ² | (4+T)x1,50 mm ² |
| Tuberías frigoríficas | Ø1/4" / Ø1/2" | Ø1/4" / Ø3/8" |
| Carga fábrica / Carga adicional | 0,69 kg / 0,012 kg | 0,69 kg / 0,012 kg |
| Longitud máx. tuberías | 25 m | 25 m |
| Desnivel máx. | 10 m | 10 m |

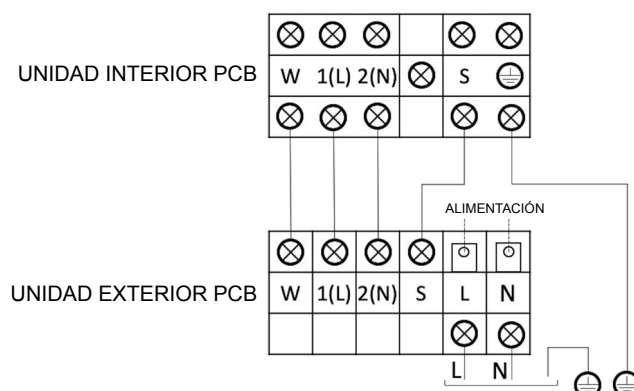
ESQUEMA CONEXIONES



NOTAS:
 (1) Los datos y especificaciones presentes en esta ficha pueden variar sin previo aviso.
 (2) Las imágenes de esta ficha son de carácter orientativo, pudiendo ser diferentes a la máquina final.

DIMENSIONES Y PESO UNIDAD INTERIOR

| Modelo | Peso | W | H | D |
|--------------------------------|----------|--------|--------|--------|
| MSFAAU-09HRFN8-QRD6GW-H | 10,70 kg | 940 mm | 325 mm | 193 mm |
| MSFAAU-12HRFN8-QRD6GW-H | 10,70 kg | 940 mm | 325 mm | 193 mm |

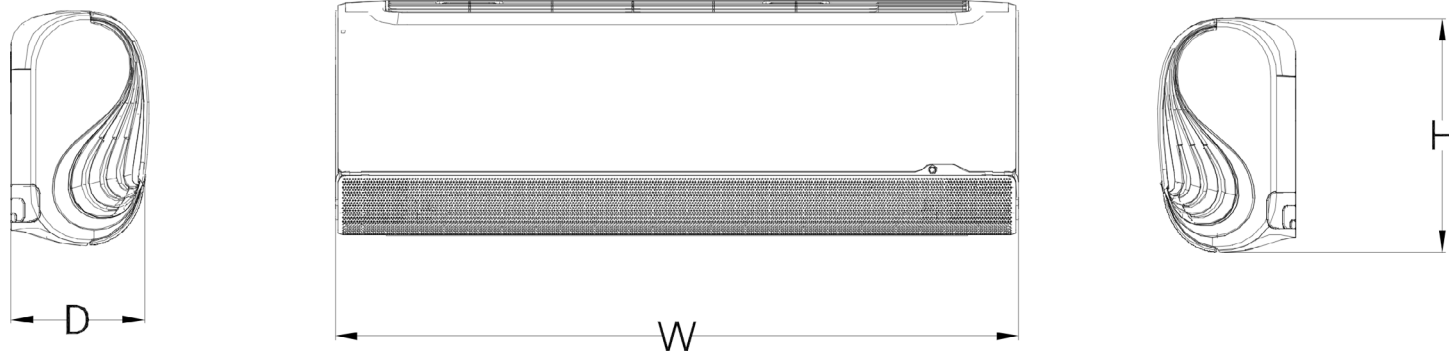

DIMENSIONES Y PESO UNIDAD EXTERIOR

| Modelo | Peso | Ancho | Alto | Fondo |
|-------------------------------|----------|--------|--------|--------|
| MOB01-09HFN8-QRD6GW(A) | 29,30 kg | 800 mm | 554 mm | 333 mm |
| MOB01-12HFN8-QRD6GW(A) | 29,30 kg | 800 mm | 554 mm | 333 mm |

